

DAINTREE SEAT RECYCLED PLASTIC



Metal Art Limited
Street & Park Furniture



Daintree Seats—1.1m above and 3.6m below



The main difference between the Daintree Seat and its recycled plastic sister the Kimberley is in the Daintree's additional seat slat on the horizontal plane. To accommodate that enhancement, the supports transition to the vertical on a sharp angle rather than a curve.

This extra slat gives the Daintree Seat that little bit extra substance and seating support, where the lighter Kimberley may not quite meet the user group needs.

As with the Kimberley, the Daintree Seat comes in three stock lengths. It is often installed with powder coated steel arm rests affixed, for even more comfort.

The Daintree Seat is available in all the standard Replas furniture colours.



The standard 1.8m Daintree Seat with three supports



Metal Art Ltd

51 Port Road, Seaview
Wellington, New Zealand
Ph +64 4 939-6666
Fax +64 4 939-6696
info@metalart.co.nz
www.metalart.co.nz



DAINTREE SEAT RECYCLED PLASTIC



Metal Art Limited
Street & Park Furniture

DESCRIPTION

Popular seven-slat seat made from Replas recycled plastic and available in a range of lengths.

SLAT DIMENSIONS

Section - 40 x 90mm

- Length 1100mm (2 supports)
 1800mm (3 supports)
 1800mm (2 supports
with steel frame)
 3600mm (5 supports)
 3600mm (3 supports
with steel frame)

SLAT COLOUR

- Green
 Grey
 Blue
 Brown

SUPPORT COLOUR

- Black

MOUNTING

- Free standing
 Surface fixed

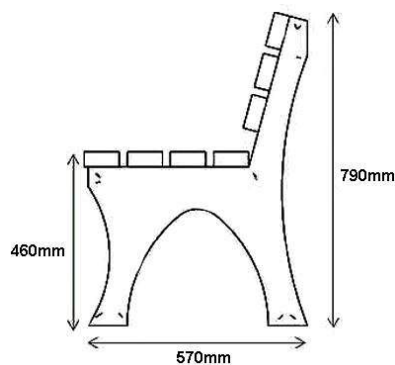

Surface fixed or free-standing



Metal Art Ltd

51 Port Road, Seaview
Wellington, New Zealand
Ph +64 4 939-6666
Fax +64 4 939-6696
info@metalart.co.nz
www.metalart.co.nz

